

EPCOS (TDK) B82464A4224K000 alternative



BCE1004-221M-LF



RoHS Compliant

SPECIFICATION APPROVAL

CUSTOMER : BEC Distribution

PRODUCT : BCE1004-221M-LF

Pb-free

CODE NO. : C00310052

CUS. CODE :

SPEC.NO. : C-0310-052(00)

DATE : 23-Jul-10

CUSTOMER APPROVAL

BEC DISTRIBUTION Ltd.

www.bec.co.uk

email: sales@bec.co.uk

Phone: +44(0)1844 275824

PREPARED BY	APPROVED BY	AUTHORIZED BY
JEAN	TONY	MASCOT

EPCOS (TDK) B82464A4224K000 alternative



PRODUCT	BCE1004-221M-LF	COIL SPECIFICATION	DATE	2010/7/23
SPEC.NO.	C-0310-052(00)		CODE NO.	C00310052

EXTERNAL DIMENSIONS :

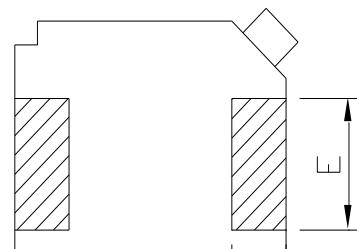
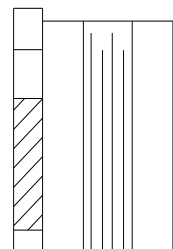
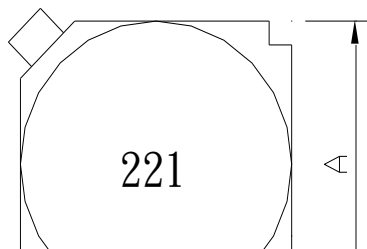

- A : 10.0±0.3 m/m
- B : 10.0±0.3 m/m
- D : 4.6±0.3 m/m
- E : 2.4±0.2 m/m
- F : 2.0±0.2 m/m

ELECTRICAL CHARACTERISTIC :

- L(μH) : 220±20% 100KHz 0.25V
- DCR(Ω) : 0.73 Max.
- IDC(A) : 0.8 Max. (L0.8A MAX ≥ 0Ax90%)
- INDUCTANCE DROP :10% Typ. @ IDC 0.8 A
- Operating Temperature Range :-40°C ~ + 125°C

IG :

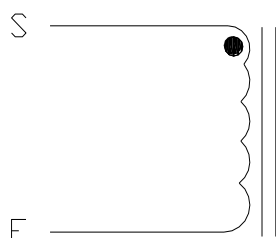

ϕ Ts(Ref.)

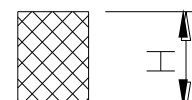
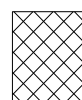

- G : 5.7 m/m
- H : 2.8 m/m
- I : 2.5 m/m

MATERIAL LIST :

NO	ITEM	MATERIAL	SUPPLIER OF THE MATERIAL
1			
2			
3			
4			
5			

EPCOS (TDK) B82464A4224K000 alternative



PRODUCT	BCE1004-221M-LF	COIL SPECIFICATION	DATE	2010/7/23
SPEC.NO.	C-0310-052(00)		CODE NO.	C00310052

TEST DATA

ELECTRICAL CHARACTERISTICS							
MEAS. ITEM	L(μH)	DCR(Ω)	IDC(A)				
TEST FREQ.	100KHz 0.25V	Max.	Max.				
YOUR			L(0.8A)				
SPEC.	220±20%	0.73	≥ 0Ax90%				
1							
2							
3							
4							
5							
6							
7							
8							
9							
10							
X	#DIV/0!	#DIV/0!	#DIV/0!				
R	0.00	0.00	0.00				

DIMENSION							
MEAS. ITEM	A	B	C	D	E	F	
TEST FREQ.	m/m	m/m	m/m	m/m	m/m	m/m	
YOUR							
SPEC.	10.0±0.3	10.0±0.3		4.6±0.3	2.4±0.2	2.0±0.2	
1							
2							
3							
4							
5							
6							
7							
8							
9							
10							
X	#DIV/0!	#DIV/0!	#DIV/0!	#DIV/0!	#DIV/0!	#DIV/0!	
R	0.00	0.00	0.00	0.00	0.00	0.00	

EPCOS (TDK) B82464A4224K000 alternative



PRODUCT	BCE1004-221M-LF	COIL SPECIFICATION	DATE	2010/7/23
SPEC.NO.	C-0310-052(00)		CODE NO.	C00310052
TEST ITEMS	SPECIFICATIONS	TEST CONDITIONS / TEST METHODS		
<u>ELECTRICAL PERFORMANCE TEST</u>				
L	REFER TO STANDARD ELEC-TRICAL CHARACTERISTIC LIST.	CH-1061 OR EQUIV.		
DCR		CH-502A OR EQUIV		
RATED CURRENT		APPLIED THE CURRENT TO COILS THE INDUCTANCE CHANGE SHOULD BE LESS THAN 10% TO INITIAL VALUE AND TEMPERATURE RISE SHOULD NOT BE MORE THAN 40°C..		
TEMPERATURE RISE TEST		1. APPLIED THE ALLOWED DC CURRENT FOR 4 HOURS. 2. TEMPERATURE MEASURE BY DIGITAL SURFACE THERMOMETER.		
OVER LOAD TEST	NO EVIDENCE OF ELECTRICAL DAMAGE	APPLIED 1.5 TIMES OF RATED ALLOWED DC CURRENT TO INDUCTORS FOR A PERIOD OF 5 MINUTES.		
<u>MECHANICAL PERFORMANCE TEST</u>				
SOLDER HEAT RESISTANCE	1. INDUCTORS SHOULD HAVE NO EVIDENCE OF ELECTRICAL AND MECHANICAL DAMAGE 2. INDUCTANCE SHOULD NOT CHANGE MORE THAN ±10% 3. SOLDER MATERIAL WILL BE LEAD FREE.	PREHEAT:150°C 60SECS SOLDER TEMPERATURE 255±5°C FLUX: ROXIN.. DIP TIME:10±0.5SECS.		
VIBRATION TEST (LOW FREQUENCY)		1.AMPLITUDE: 1.5 mm 2.FREQUENCY: 10-55-10HZ / 1 MIN 3.DIRECTION: X, Y, Z 4.DURATION: 2 HRS/X, Y, Z		
SHOCK TEST		INDUCTORS SHOULD BE DROPPED 10 TIMES FROM A HEIGHT OF 1m ONTO 3cm WOODEN BOARD.		

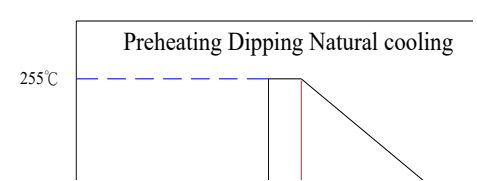

EPCOS (TDK) B82464A4224K000 alternative



PRODUCT	BCE1004-221M-LF	COIL SPECIFICATION	DATE	2010/7/23
SPEC.NO.	C-0310-052(00)		CODE NO.	C00310052
TEST ITEMS	SPECIFICATIONS	TEST CONDITIONS / TEST METHODS		
<u>MECHANICAL PERFORMANCE TEST</u>				
SOLDERABILITY TEST	MORE THAN 90% OF TERMINAL ELECTRODE SHOULD BE COVERED WITH SOLDER.	AFTER FLUXING, INDUCTOR SHALL BE DIPPED IN A MELTED SOLDER BATH AT 255±5°C FOR 5 SECONDS		
COMPONENT ADHESION (PUSH TEST)	1.5Kg Min	THE DEVICE SHOULD BE REFLOW SOLDERED (255±5°C FOR 10 SECONDS) TO A TINNED COPPER SUBSTRATE. A DYNOMETER FORCE GAUGE SHOULD BE APPLIED TO THE SIDE OF THE COMPONENT. THE DEVICE MUST WITH- STAND A MINIMUM FORCE OF 1.5Kg WITHOUT AILURE OF THE TERMINATION . ATTACHED TO COMPONENT.		
COMPONENT ADHESION (PULL TEST)	1.5Kg Min	1.INSERT 10cm WIRE INTO THE REMAINING OPEN EYE BEND THE ENDS OF EVEN WIRE LENGTHS UPWARD AND WIND TOGETHER 2. TERMINAL SHALL NOT BEREMARKABLY DAMAGED		
FLEXTURE STRENGTH	THE FORCES APPLIED SHOULD NOT DAMAGE THE DIELECTRIC.	SOLDER A CHIP ON A TEST SUBSTRATE, BEND THE SUBSTRATE BY 2mm AND RETURN.		
RESISTANCE TO SOLVENT TEST	THERE SHOULD BE NO CASEDEFORMATION, CHANGE IN APPEARANCE OR BITERATION OF MARKING	INDUCTERS SHALL WITHSTAND 6 MINTES OF ALCOHOL		

EPCOS (TDK) B82464A4224K000 alternative



PRODUCT	BCE1004-221M-LF	COIL SPECIFICATION	DATE	2010/7/23
SPEC.NO.	C-0310-052(00)		CODE NO.	C00310052
TEST ITEMS	SPECIFICATIONS	TEST CONDITIONS / TEST METHODS		
<u>CLIMATIC TEST</u>				
TEMPERATURE CHARACTERISTIC	1.APPEARANCE:NO DAMAGE 2.INDUCTANCE:WITHIN±10% OF INITIAL VALUE.	- 40°C ~ +125°C		
HUMIDITY TEST		60°C±2°C / 96±2 HOURS		
LOW TEMPERATURE STORAGE		1.TEMPERATURE:- 25°C±2°C 2.TIME: 96±2 HOURS		
THERMAL SHOCK TEST		1.-25±5°C FOR 30 MINUTES. +80±5°C FOR 30 MINUTES. 2.TOTAL: 10 CYCLES		
HIGH TEMPERATURE STORAGE		1.APPLIED CURRENT: MAX RATED CURRENT 2.TEMPERATURE:80°C±2°C		
NOTE : INDUCTORS ARE TO BE TESTED AFTER 2 HOUR AT ROOM TEMPERATURE.				
<u>LIFE TEST</u>				
HIGH TEMPERATURE LOAD LIFE TEST	INDUCTORS SHOULD BE NO EVIDENCE OF SHORT OR OPEN CIRCUIT	1. TEMPERATURE: 80±2°C 2. TIME: 500±12 HOURS 3. LOAD: ALLOWED DC CURREN		
HUMIDITY LOAD LIFE TEST		1. TEMPERATURE: 60±2°C 2. R.H.: 90-95% 3. TIME: 500±12 HOURS 4. LOAD: ALLOWED DC CURREN		

PRODUCT	BCE1004-221M-LF	COIL SPECIFICATION	DATE	2010/7/23
SPEC.NO.	C-0310-052(00)		CODE NO.	C00310052

RECOMMENDED SOLDERING CONDITIONS :

CLASSIFICATION REFLOW PROFILES

Profile Feature	Sn-Pb Eutectic Assembly		Pb-Free Assembly	
	Large Body	Small Body	Large Body	Small Body
Average ramp-up rate (T _L to T _P)	3°C/second max.		3°C/second max.	
Preheat				
-Temperature Min (T _{Smin})	100°C		150°C	
-Temperature Min (T _{Smax})	150°C		200°C	
-Time (min to max) (ts)	60-120 seconds		60-180 seconds	
T _{Smax} to T _L				
-Ramp-up Rate			3°C/second max.	
Time maintained above:				
-Temperature (T _L)	183°C		217°C	
-Time (t _L)	60-150 seconds		60-150 seconds	
Peak Temperature (T _P)	225 +0/-5°C	240 +0/-5°C	245 +0/-5°C	255 +5/-5°C
Time within 5°C of actual Peak Temperature (t _p)	10-30 seconds	10-30 seconds	10-30 seconds	20-40 seconds
Ramp-down Rate	6°C/second max.		6°C/second max.	
Time 25°C to Peak Temperature	6 minutes max.		8 minutes max.	

Note : All temperatures refer to top side of the package. Measured on the package body surface.

REFLOW SOLDERINGS

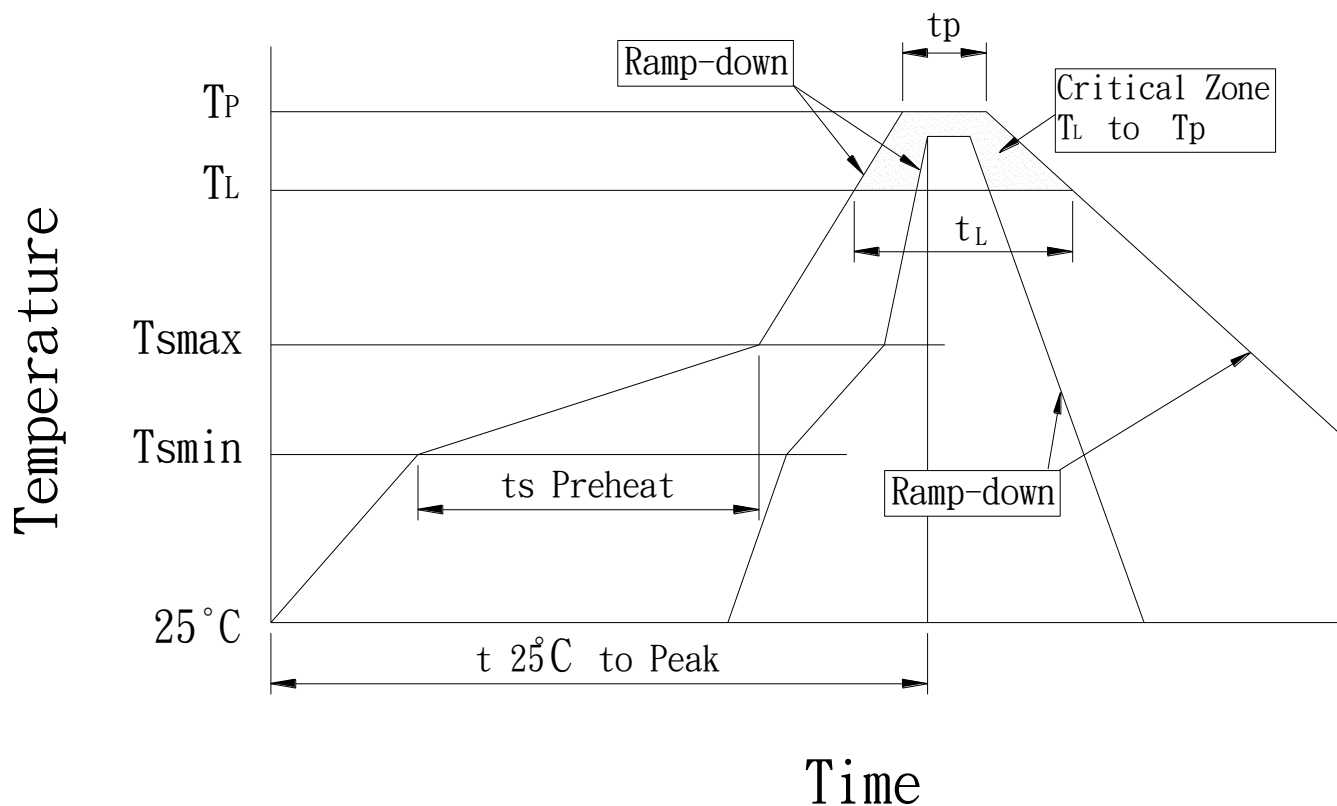

EPCOS (TDK) B82464A4224K000 alternative



PRODUCT	BCE1004-221M-LF	COIL SPECIFICATION	DATE	2010/7/23
SPEC.NO.	C-0310-052(00)		CODE NO.	C00310052

PACKAGE :

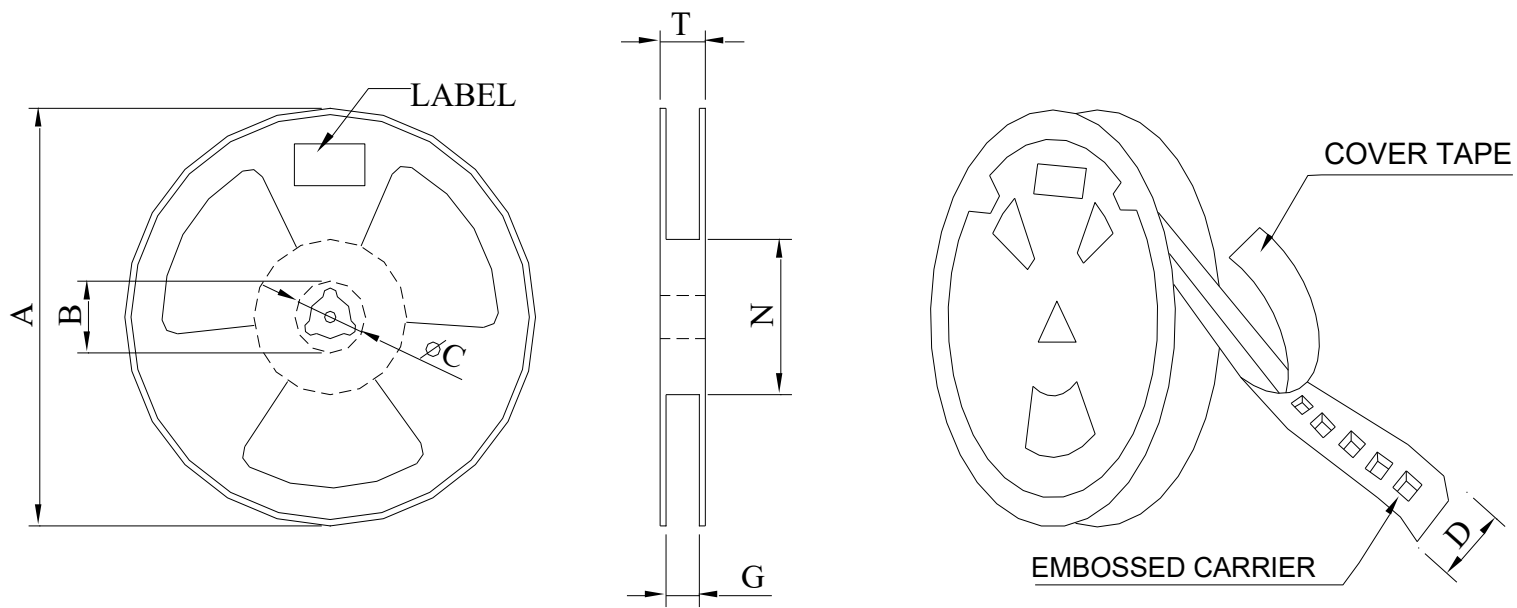

*CARRIER TAPE WIDTH : D

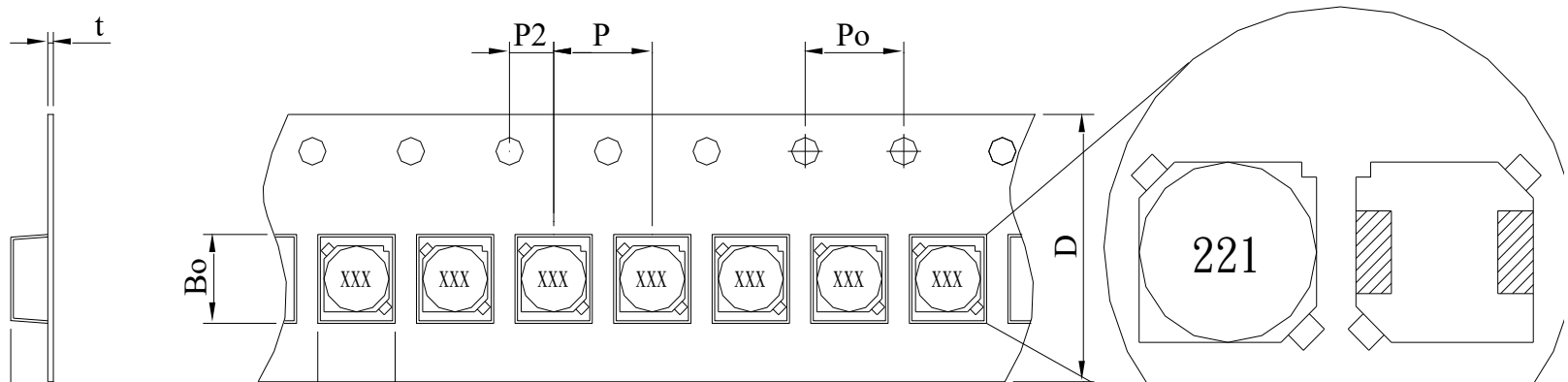

STAYLE	DIMENSIONS (m/m)														
	Q'TY (PCS)	A	B	C	D	G	N	T	Ao	Bo	Ko	t	P	Po	P2
13-24	600	330	21 ± 0.8	13 ± 0.5	24	26 ⁺⁰	50 ⁻⁰	30.4	—	—	—	—	16	4	—

EPCOS (TDK) B82464A4224K000 alternative



PRODUCT	BCE1004-221M-LF	COIL SPECIFICATION	DATE	2010/7/23
SPEC.NO.	C-0310-052(00)		CODE NO.	C00310052

TABLE :



INNER BOX LABEL

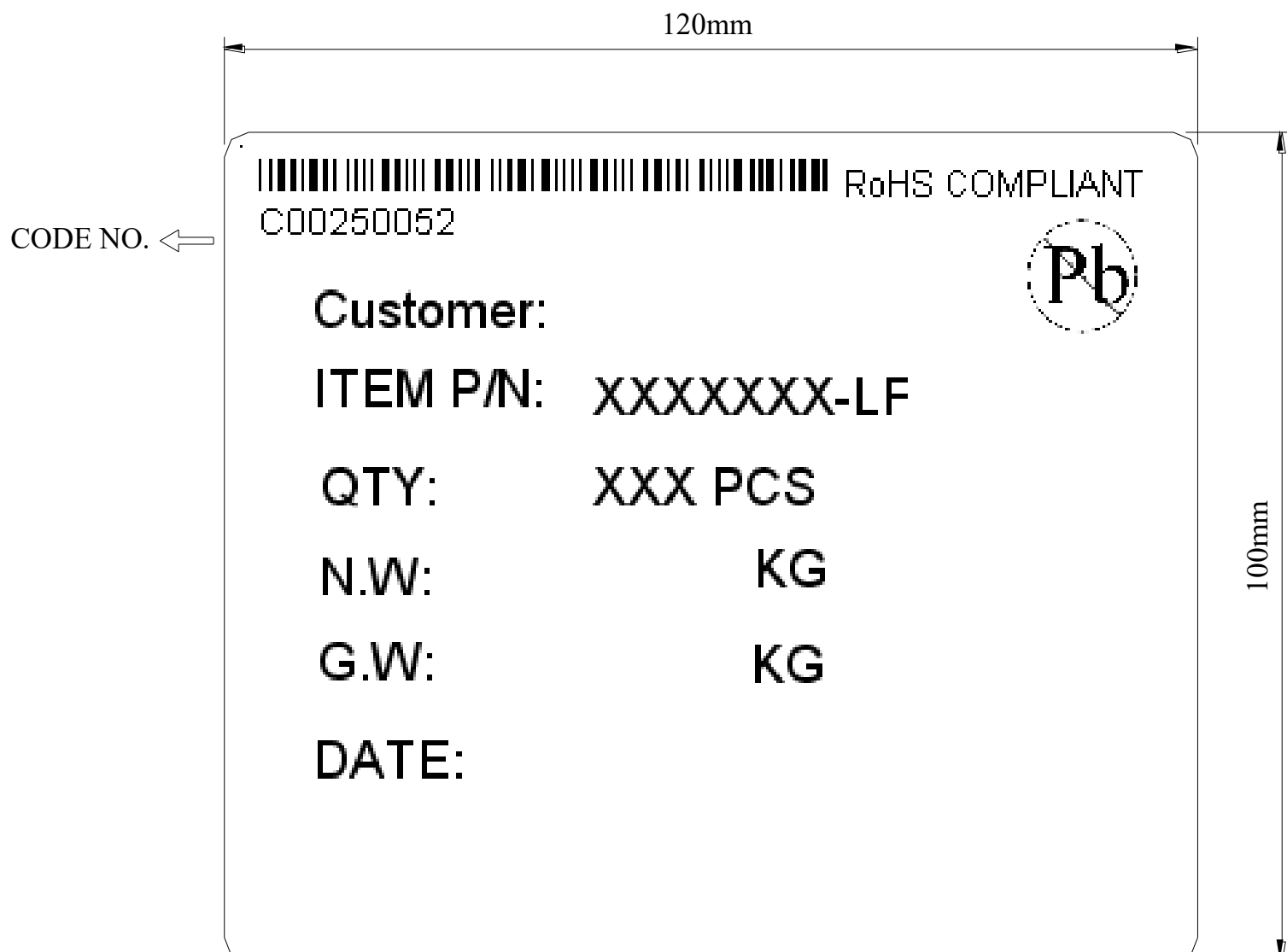

OUT BOX LABEL